



Trellis Bucket Purse

Finished Size:

Approximately:
10 1/2" H x 12" W x 2 1/2" D, 27" Straps

Materials:

Worsted Weight Acrylic Yarn,
approximately:

Main Color (MC) Red Heart (Medium
Thyme) – 14 ounces (396 grams, 728 yards)

Crochet hook size: H (5.0 mm) or size
needed for gauge

Crochet hook size: G (4.5 mm) or size
needed for gauge

Yarn needle

Matching Fabric – 1 yd of 45" W fabric

Sewing Needle

Sewing Thread (to match fabric)

Optional: 9" Zipper

Optional: 1 Lg. Snap Closure

Gauge 3 1/2 sc = 1 inch (H hook)
4 sc = 1 inch (G hook)

Purse

Bottom

Make **one** as follows:

With size H hook and MC, ch 21.

Rnd 1: Sc in 2nd ch from hook, sc in each ch
across to last ch, 2 sc in last st, working in
free loops of foundation ch, sc in each loop
across to last loop, 2 sc in last loop; join
with slip st in first sc. (42 sc)

Rnd 2: Ch 1, turn; 2 sc in first 2 sc, sc in
next 18 sc, 2 sc in next 3 sc, sc in next 18 sc,
2 sc in next sc; join with slip st in first sc.
(48 sc)

Rnd 3: Ch 1, turn; 2 sc in next sc, sc in next
19 sc, (2 sc in next sc, sc in next sc) **three
times**, sc in next 18 sc, (2 sc in next sc, sc in
next sc) **twice**; join with slip st in first sc.
(54 sc)

Rnd 4: Ch 1, turn; (2 sc in next sc, sc in
next 2 sc) **twice**, sc in next 18 sc, (2 sc in
next sc, sc in next 2 sc) **three times more**,
sc in next 18 sc, (2 sc in next sc, sc in next 2
sc) **once more**; join with slip st in first sc.
(60 sc)

Rnd 5: Ch 1, turn; (2 sc in next sc, sc in
next 21 sc, (2 sc in next sc, sc in next 3 sc)
three times, sc in next 18 sc, (2 sc in next
sc, sc in next 3 sc) **twice**; join with slip st in
first sc. (66 sc)

Rnd 6: Ch 1, turn; (2 sc in next sc, sc in
next sc) **twice**, sc in next 18 sc, (2 sc in next
sc, sc in next 4 sc) **three times**, sc in next 18
sc, (2 sc in next sc, sc in next 4 sc) **once
more**; join with slip st in first sc. (72 sc)

Rnd 7: Ch 1, turn; 2 sc in next sc, sc in next
23 sc, (2 sc in next sc, sc in next 5 sc) **three
times**, sc in next 18 sc, (2 sc in next sc, sc in
next 5 sc) **twice**; join with slip st in first sc.
(78 sc)

Rnd 8: Ch 1, turn; (2 sc in next sc, sc in next 6 sc) **twice**, sc in next 18 sc, (2 sc in next sc, sc in next 6 sc) **three times**, sc in next 18 sc, (2 sc in next sc, sc in next 6 sc) **once more**; join with slip st in first sc. (84 sc)

Rnd 9: Ch 1, turn; 2 sc in next sc, sc in next 25 sc, (2 sc in next sc, sc in next 7 sc) **three times**, sc in next 18 sc, (2 sc in next sc, sc in next 7 sc) **twice**; join with slip st in first sc. (90 sc)

Rnd 10: Ch 1, turn; (2 sc in next sc, sc in next 8 sc) **twice**, sc in next 18 sc, (2 sc in next sc, sc in next 8 sc) **three times**, sc in next 18 sc, (2 sc in next sc, sc in next 8 sc) **once more**; join with slip st in first sc. (96 sc)

Rnd 11: Ch 1, turn; 2 sc in next sc, sc in next 27 sc, (2 sc in next sc, sc in next 9 sc) **three times**, sc in next 18 sc, (2 sc in next sc, sc in next 9 sc) **twice**; join with slip st in first sc. (102 sc)

Rnd 12: Ch 1, turn; (2 sc in next sc, sc in next 10 sc) **twice**, sc in next 18 sc, (2 sc in next sc, sc in next 10 sc) **three times**, sc in next 18 sc, (2 sc in next sc, sc in next 10 sc) **once more**; join with slip st in first sc. (108 sc)v

Rnd 13: Ch 1, **do not turn**; FPsc around post of each sc around; join with slip st in first sc. (108 sc)

Purse Body (Trellis St)

Rnd 14: (**Right Side**) Ch 1, turn; (sc in each sc around; join with slip st in first sc. (108 sc)

Rnd 15: Ch 2, turn; dc in each sc around; join with slip st in first sc. (108 dc)

Rnd 16: Ch 1, turn; skip first dc, FPtr around post of sc below middle dc of next 3 dc (in Rnd 15), sc in next 3 sc of current rnd, *skip next dc, FPtr together around same post as previous FPtr **and** around post of sc

below middle dc of next 3 dc (in Rnd 15), sc in next 3 dc, repeat from * around, FPtr around post of previous FPtr, slip st in first FPtr of current rnd. (108 st)

Rnd 17: Ch 2, turn; dc in each st around; join with slip st in first dc. (108 dc)

Rnd 18: Ch 1, turn; sc in next 2 dc, FPtr together around both posts of FPtr below **and** both posts of next diamond below, skip next dc, sc in next 3 dc, * FPtr together around both posts of diamond below **and** next diamond, skip next dc, sc in next 3 dc; repeat from * around to last 2 dc, skip next dc, sc in last dc; join w/slip st in first sc. (108 st)

Rnd 19: Ch 2, turn; dc in each st around; join with slip st in first dc. (108 dc)

Rnd 20: Ch 1, turn; *FPtr together around both posts of diamond below **and** next diamond, skip next dc, sc in next 3 dc, repeat from * around; join with slip st in first FPtr of current rnd. (108 st)

Rnds 21 - 44: Repeat Rnds 17-20 **six times more**.

Rnd 45: Ch 1, turn; sc in each st around, join with slip st in first sc. (108 sc)

Rnd 46: Ch 1, turn; work Crab st in each sc around; join with slip st in Crab st. (see pg. 6 for Crab stitch instructions)

Finish off. Weave in ends.

Shoulder Straps

Make **two** as follows:

With G hook and MC, ch 129 (foundation ch).

Row 1: (**Right Side**) Ch 1, turn; sc in 2nd ch from hook, sc in each sc across. (128 sc)

Row 2: Ch 2, turn; dc in each sc across.
(128 dc)

Row 3: Ch 1, turn; skip first dc, FPtr around post of sc below middle dc of next 3 dc (in Row 1), sc in next 3 dc of current row, *skip next dc, FPtr together around same post as previous FPtr **and** around post of sc below middle dc of next 3 dc (in Row 1), sc in next 3 dc, repeat from * to last 3 dc, skip next dc, FPtr around post of previous FPtr, sc in last 2 dc. (128 st)

Row 4: Ch 2, turn; dc in each st across.
(128 st)

Row 5: Ch 1, turn; sc in next 2 dc, FPtr together around post of FPtr below and both posts of next diamond below, skip next dc, sc in next 3 dc, *FPtr together around same post as previous FPtr **and** around both posts of next diamond, skip next dc, sc in next 3 dc, repeat from * across to last st, sc in last dc. (128 st)

Row 6: Ch 1, **do not turn**; Crab st in each st across. (128 st)

Finish off.

With **Right Side** still facing, turn work 180 degrees. With G hook, join MC in between the first two sc of Row 1.

Ch 1, Crab st in between each sc across.

Finish off.

Weave in ends.



Cut (2) pcs of fabric 2 1/2" W x 32" L.

Fold fabric in half lengthwise, press with an iron to make a slight crease in the middle. Open the fold, then fold each side in to the middle crease. Press both sides.

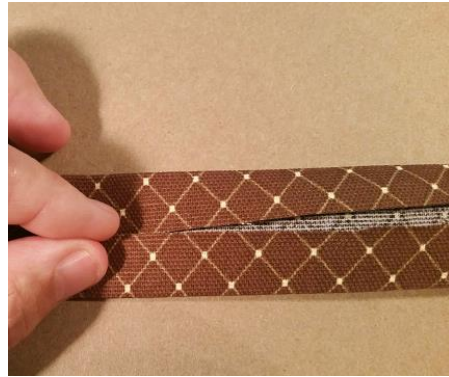

Turn crocheted strap where wrong side is facing up. Turn fabric strip over so folded sides are hidden against the crocheted strap and pin in place as shown:



With sewing needle and thread, stitch fabric strip to crocheted strap on both sides lengthwise.



Repeat for second strap.

Liner

Cut (2) pieces of fabric 15" W x 18" H. With **right sides** of fabric facing each other, pin around sides and bottom. Using matching thread, machine or hand stitch pieces together with a 3/8" seam, leaving a 15" opening at the top.

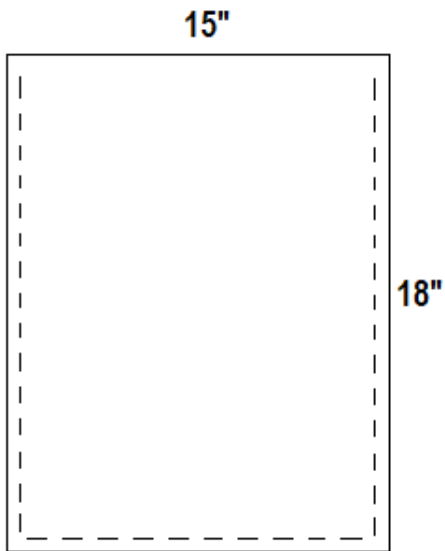

With wrong sides of fabric facing out, sew a 3/8" seam around sides and bottom.

Fold one of the bottom corners to a triangle point.

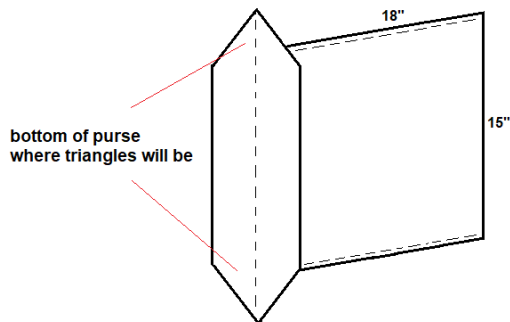

Measure down from point until straight edge is 6" across with seam in center.

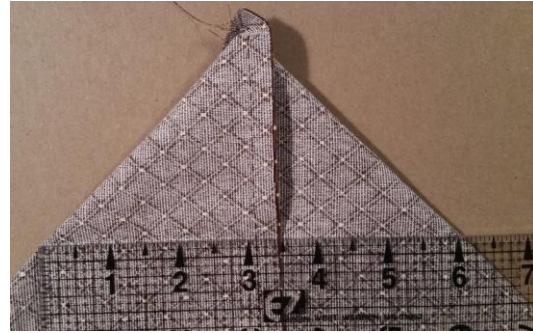

Mark a line straight across with an ink pen, then make a small curve above the line as shown below for a more fitted appearance of lining:



Pin and stitch along the curve. Cut corner off approximately 1/4" away from seam.



Repeat for other corner.

Position straps inside purse 2" below top edge of purse, 2 1/2" in from sides and secure with stitches using MC and yarn needle, as shown:

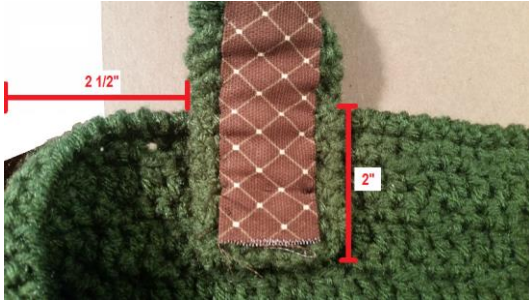

If you would like to have a zipper pocket in the side of the purse, pause here and do instructions for Optional Zipper Pocket below.

*To finish, place liner inside purse with wrong side of liner facing wrong side of purse body. Trim top of liner to 1" above edge of purse. Fold edges under until 1/2" below edge of purse on the inside. With sewing needle and thread, stitch liner to purse.

Optional Zipper Pocket

Cut a piece of fabric 7 1/2" H x 11" W. Fold over top and bottom 1/2" and press with an iron. Next, fold over sides 3/8" and press as well.



Cut another piece of fabric 3 1/2" H x 11" W. On **wrong side** of fabric, draw a lined box 3/8" H x 9" L as indicated in the diagram below:

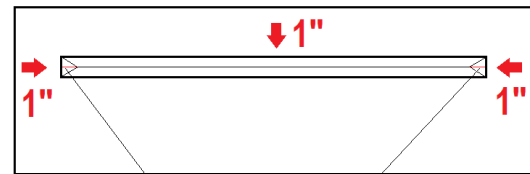

3/8" wide line to create triangles



Place small fabric **wrong side** facing on top of **right side** of larger fabric piece. Insure top edge of small piece lays on the top ironed seam of large piece.

Pin in place and sew around drawn rectangle only.



Cut center line to the point of the triangles and the triangles also, all the way through both layers.

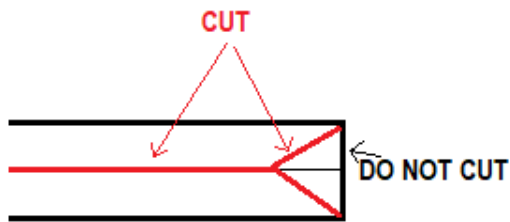

Cut along center line to the point of both triangles and also the two places where triangle branches out (red lines only in diagram). Do NOT cut the left and right side of the triangle.

Push small fabric piece through hole of larger piece. Press both sides flat with an iron.



Place zipper face down on **wrong side** of pocket. Sew zipper to pocket.

Fold ironed edges of pocket under and pin to lining where you want the pocket to go. With needle and thread, neatly stitch pocket to purse lining. Return to * to finish purse.

Optional – Add a large sew on snap inside the purse about 1/2” - 1” from top edge between straps for closure.

To embellish, add a purse charm for decoration.

Abbreviations and Stitch Instructions

beg	beginning
ch (s)	chain (s)
chg	changing
dc	double crochet(s)
dr	dropped
fin	finish (ing)
hdc	half double crochet(s)
MC	Main Color
mm	millimeters
Rnd(s)	Round(s)
sc	single crochet(s)
sp(s)	space(es)
st(s)	stitch(es)
tr	treble crochet(s)
YO	yarn over

Gauge

Gauge mentioned at the beginning of pattern instructions may need adjusting, depending upon your needle, deviation from type of yarn suggested, or other factors. Make an example piece and measure, then adjust needle size to obtain gauge.

Changing colors

Work the last stitch to the last step of completing that stitch. Hook next color and draw thru loops on hook.

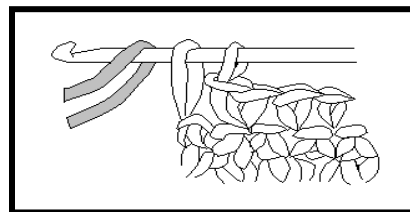

Crab Stitch

(also known as “Reverse sc”) – **working from left to right**, insert hook in next st, YO, pull up loop, YO, draw through both loops on hook.

Whipstitch

Insert needle through top loops only of both pieces, draw thru, insert needle in same place and draw thru again to secure beginning of seam (remember to leave enough yarn to weave in later). Insert needle thru top loops of stitches, **back to front** across to end specified in pattern. Weave in end, cut yarn close to work.

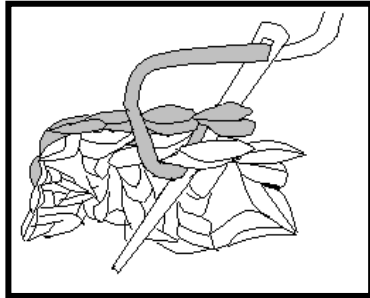

Weaving In Ends

Ends can be woven in securely by loading loose end into yarn needle, pull loaded needle through a few stitches, then back in the other direction a few stitches. Cut yarn close to work.

Important note

Great strides have been taken to insure accuracy of patterns. Work may vary depending upon human error or individuality of work. Patterns have been made and instructions have been tested to insure accuracy. For any problems with pattern, please send an email to patterns@NeedleMeThat.com or write us at Needle Me That, PO Box 632, Andrews, SC 29510.

© 2018 Vicki Moore

www.NeedleMeThat.com